

**STEP 5.** Mount power supply in wall with screws provided and attach TV set cable to jack on front. Connect band separator to VHF and UHF antenna terminals of TV set, if required. Press switch on front of outlet and check that light is on.

Figure 4

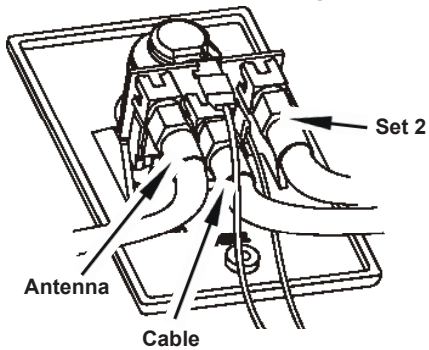

**OPERATION: To receive cable signals from outdoor receptacle:** Press switch to OFF (CABLE) position. Light on wall plate will go off showing that power is no longer connected to the antenna and that both TV sets are receiving signals from outdoor receptacle.

**To receive signals from antenna:** Press switch to ON (ANT) position. Light on wallplate will come on showing that power is connected to the antenna and both TV sets are receiving signals from the antenna.

**NOTE:** Make sure the antenna is in the operating position (up) and pointed at the station desired.

**STEP 5.** Mount power supply in wall with screws provided and attach TV set cable to jack on front. Connect band separator to VHF and UHF antenna terminals of TV set, if required. Press switch on front of outlet and check that light is on.

Figure 4

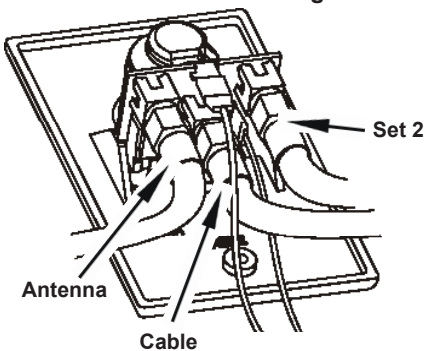

**OPERATION: To receive cable signals from outdoor receptacle:** Press switch to OFF (CABLE) position. Light on wall plate will go off showing that power is no longer connected to the antenna and that both TV sets are receiving signals from outdoor receptacle.

**To receive signals from antenna:** Press switch to ON (ANT) position. Light on wallplate will come on showing that power is connected to the antenna and both TV sets are receiving signals from the antenna.

**NOTE:** Make sure the antenna is in the operating position (up) and pointed at the station desired.

**STEP 5.** Mount power supply in wall with screws provided and attach TV set cable to jack on front. Connect band separator to VHF and UHF antenna terminals of TV set, if required. Press switch on front of outlet and check that light is on.

Figure 4

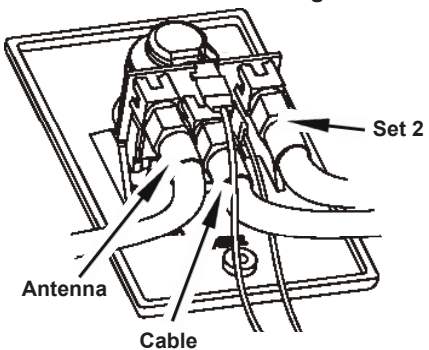

**OPERATION: To receive cable signals from outdoor receptacle:** Press switch to OFF (CABLE) position. Light on wall plate will go off showing that power is no longer connected to the antenna and that both TV sets are receiving signals from outdoor receptacle.

**To receive signals from antenna:** Press switch to ON (ANT) position. Light on wallplate will come on showing that power is connected to the antenna and both TV sets are receiving signals from the antenna.

**NOTE:** Make sure the antenna is in the operating position (up) and pointed at the station desired.

**INSTALLING FC-5910 CONNECTORS ON COAX CABLE**

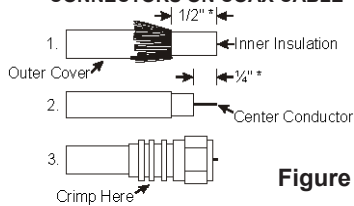

Figure 5

**STEP 1:** Strip outer cover back 1/2" from end of cable. Fray braid back as far as outer cover will allow.

**STEP 2:** Trim braid close to outer cover and remove 1/4" of inner insulation **being careful not to nick center conductor.** Make sure no foil or braid can touch center conductor.

**STEP 3:** Slide connector tip between braid and inner insulation (braid and foil, on foil shield cable) and push connector on cable as far as it will go. Crimp built-in ferrule with proper crimping tool. **Hex connector requires hex crimping tool. Do Not** crush cable out-of-round. \* If installing in very hot weather, increase these dimensions 1/8".

**WINEGARD MOBILE PRODUCTS LIMITED WARRANTY (2 YEARS PARTS; 1 YEAR LABOR)**

Winegard Company warrants this product against defects in materials or workmanship for a period of two (2) years from the date of original purchase. During year one (1) of such warranty, Winegard Company will also pay authorized labor costs to an authorized Winegard dealer to repair or replace defective products. No warranty claim will be honored unless at the time the claim is made, Customer presents proof of purchase to an authorized Winegard dealer (to locate the nearest authorized Winegard dealer, contact Winegard Company, 3000 Kirkwood Street, Burlington, Iowa 52601, Telephone 800-288-8094 or visit [www.winegard.com](http://www.winegard.com)). Customer must provide proof of purchase with a dated sales receipt for the Winegard product to verify the product is under warranty. If the date of purchase cannot be verified, the warranty period shall be considered to begin thirty (30) days after the date of manufacture.

If a defect in material or workmanship is discovered, Customer may take the product to an authorized Winegard dealer for service. Customer must provide proof of purchase to verify the product is under warranty. If the product is brought to an authorized Winegard dealer for service prior to expiration of year one (1) of the warranty period and a defect in material or workmanship is verified by Winegard Technical Services, Winegard Company will cover the Winegard dealer's labor charges for warranty service. The Winegard dealer must contact Winegard Technical Services in advance for pre-approval of the service. Approval of the service is at the sole discretion of Winegard Company.

Alternatively, Customer may ship the product prepaid to Winegard Technical Services (located at 3111 Kirkwood Street, Burlington, Iowa 52601, Telephone 800-788-4417). Customer must return the product along with a brief description of the problem and provide Winegard Technical Services with Customer's name, address, and phone number. Customer must also provide proof of purchase to verify the product is under warranty. If the product is returned before the expiration of the warranty period, Winegard Company will (at its option) either repair or replace the product.

This Limited Warranty does not apply if the product has been damaged, deteriorates, malfunctions or fails from: improper installation, misuse, abuse, neglect, accident, tampering, modification of the product as originally manufactured by Winegard in any manner whatsoever, removing or defacing any serial number, usage not in accordance with product instructions or acts of nature such as damage caused by wind, lightning, ice or corrosive environments such as salt spray and acid rain. This Limited Warranty also does not apply if the product becomes unable to perform its intended function in any way as a result of the television signal provider making any changes in technology or service.

**RETURN AUTHORIZATION POLICY**

A Return Material Authorization (RMA) is required prior to returning any product to Winegard Company or Winegard Warranty Services under this warranty policy. Please call our Technical Services Department at 800-788-4417 or send an e-mail to [warranty@winegard.com](mailto:warranty@winegard.com) to obtain the RMA number. Please furnish the date of purchase when requesting an RMA number. Enclose the product in a prepaid package and write the RMA number in large, clear letters on the outside of the package. To avoid confusion or misunderstanding, a shipment(s) without an RMA number(s) or an unauthorized return(s) will be refused and returned to Customer freight collect.

WINEGARD COMPANY DOES NOT ASSUME ANY LIABILITIES FOR ANY OTHER WARRANTIES, EXPRESS OR IMPLIED, MADE BY ANY OTHER PERSON. ALL OTHER WARRANTIES WHETHER EXPRESS, IMPLIED OR STATUTORY INCLUDING WARRANTIES OF FITNESS FOR A PARTICULAR PURPOSE AND MERCHANTABILITY ARE LIMITED TO THE TWO YEAR PERIOD OF THIS WARRANTY.

In states that do not allow limitations on implied warranties, or the exclusion of limitation of incidental or consequential damages, the above limitations or exclusions do not apply.

Some states do not allow limitations on how long an implied warranty lasts, or the exclusion of limitation of incidental or consequential damages, so the above limitations or exclusions may not apply to you.

This warranty gives Customer specific legal rights. Customer may also have other rights that may vary from state to state.

**SATELLITE RECEIVER WARRANTY**

See manufacturer's limited warranty policy. WS-MOBWARREREV 2 Rev.1/10

**INSTRUCTIONS**



**WINEGARD®**

MODELS RV-7012, RV-7032, RV-7042

Made in U.S.A.

**RV WALL PLATE/ POWER SUPPLY**

This unit is equipped with a polyswitch, (current limiting device), which will shut down +12VDC if there is a direct short between antenna and power supply. Green indicator light will not light. Once short is eliminated, device will reset itself in approximately 2 minutes.

**DESCRIPTION**

Wall plate/power supply to operate Winegard RV antenna with outdoor receptacle for TV set and cable input. Wall plate/power supply provides +12VDC to antenna and +12 volt receptacle as well as antenna signals to two TV sets. Cable input from outdoor receptacle connects to wall plate and may be switched so either antenna or cable signals may be watched. See applications.

**NOTE: THIS UNIT IS NOT AN AMPLIFIER. USE ONLY WITH A WINEGARD AMPLIFIED RV ANTENNA.**

**WINEGARD COMPANY**

3000 KIRKWOOD ST., BURLINGTON, IA 52601-2000  
Printed in U.S.A. 2451486 Rev.2 1/10

**INSTRUCTIONS**



**WINEGARD®**

MODELS RV-7012, RV-7032, RV-7042

Made in U.S.A.

**RV WALL PLATE/ POWER SUPPLY**

This unit is equipped with a polyswitch, (current limiting device), which will shut down +12VDC if there is a direct short between antenna and power supply. Green indicator light will not light. Once short is eliminated, device will reset itself in approximately 2 minutes.

**DESCRIPTION**

Wall plate/power supply to operate Winegard RV antenna with outdoor receptacle for TV set and cable input. Wall plate/power supply provides +12VDC to antenna and +12 volt receptacle as well as antenna signals to two TV sets. Cable input from outdoor receptacle connects to wall plate and may be switched so either antenna or cable signals may be watched. See applications.

**NOTE: THIS UNIT IS NOT AN AMPLIFIER. USE ONLY WITH A WINEGARD AMPLIFIED RV ANTENNA.**

**WINEGARD COMPANY**

3000 KIRKWOOD ST., BURLINGTON, IA 52601-2000  
Printed in U.S.A. 2451486 Rev.2 1/10

**INSTALLING FC-5910 CONNECTORS ON COAX CABLE**

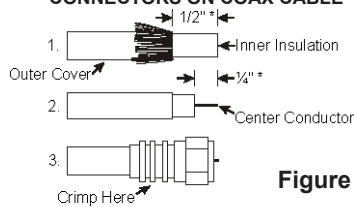

Figure 5

**STEP 1:** Strip outer cover back 1/2" from end of cable. Fray braid back as far as outer cover will allow.

**STEP 2:** Trim braid close to outer cover and remove 1/4" of inner insulation **being careful not to nick center conductor.** Make sure no foil or braid can touch center conductor.

**STEP 3:** Slide connector tip between braid and inner insulation (braid and foil, on foil shield cable) and push connector on cable as far as it will go. Crimp built-in ferrule with proper crimping tool. **Hex connector requires hex crimping tool. Do Not** crush cable out-of-round. \* If installing in very hot weather, increase these dimensions 1/8".

**WINEGARD MOBILE PRODUCTS LIMITED WARRANTY (2 YEARS PARTS; 1 YEAR LABOR)**

Winegard Company warrants this product against defects in materials or workmanship for a period of two (2) years from the date of original purchase. During year one (1) of such warranty, Winegard Company will also pay authorized labor costs to an authorized Winegard dealer to repair or replace defective products. No warranty claim will be honored unless at the time the claim is made, Customer presents proof of purchase to an authorized Winegard dealer (to locate the nearest authorized Winegard dealer, contact Winegard Company, 3000 Kirkwood Street, Burlington, Iowa 52601, Telephone 800-288-8094 or visit [www.winegard.com](http://www.winegard.com)). Customer must provide proof of purchase with a dated sales receipt for the Winegard product to verify the product is under warranty. If the date of purchase cannot be verified, the warranty period shall be considered to begin thirty (30) days after the date of manufacture.

If a defect in material or workmanship is discovered, Customer may take the product to an authorized Winegard dealer for service. Customer must provide proof of purchase to verify the product is under warranty. If the product is brought to an authorized Winegard dealer for service prior to expiration of year one (1) of the warranty period and a defect in material or workmanship is verified by Winegard Technical Services, Winegard Company will cover the Winegard dealer's labor charges for warranty service. The Winegard dealer must contact Winegard Technical Services in advance for pre-approval of the service. Approval of the service is at the sole discretion of Winegard Company.

Alternatively, Customer may ship the product prepaid to Winegard Technical Services (located at 3111 Kirkwood Street, Burlington, Iowa 52601, Telephone 800-788-4417). Customer must return the product along with a brief description of the problem and provide Winegard Technical Services with Customer's name, address, and phone number. Customer must also provide proof of purchase to verify the product is under warranty. If the product is returned before the expiration of the warranty period, Winegard Company will (at its option) either repair or replace the product.

This Limited Warranty does not apply if the product has been damaged, deteriorates, malfunctions or fails from: improper installation, misuse, abuse, neglect, accident, tampering, modification of the product as originally manufactured by Winegard in any manner whatsoever, removing or defacing any serial number, usage not in accordance with product instructions or acts of nature such as damage caused by wind, lightning, ice or corrosive environments such as salt spray and acid rain. This Limited Warranty also does not apply if the product becomes unable to perform its intended function in any way as a result of the television signal provider making any changes in technology or service.

**RETURN AUTHORIZATION POLICY**

A Return Material Authorization (RMA) is required prior to returning any product to Winegard Company or Winegard Warranty Services under this warranty policy. Please call our Technical Services Department at 800-788-4417 or send an e-mail to [warranty@winegard.com](mailto:warranty@winegard.com) to obtain the RMA number. Please furnish the date of purchase when requesting an RMA number. Enclose the product in a prepaid package and write the RMA number in large, clear letters on the outside of the package. To avoid confusion or misunderstanding, a shipment(s) without an RMA number(s) or an unauthorized return(s) will be refused and returned to Customer freight collect.

WINEGARD COMPANY DOES NOT ASSUME ANY LIABILITIES FOR ANY OTHER WARRANTIES, EXPRESS OR IMPLIED, MADE BY ANY OTHER PERSON. ALL OTHER WARRANTIES WHETHER EXPRESS, IMPLIED OR STATUTORY INCLUDING WARRANTIES OF FITNESS FOR A PARTICULAR PURPOSE AND MERCHANTABILITY ARE LIMITED TO THE TWO YEAR PERIOD OF THIS WARRANTY.

In states that do not allow limitations on implied warranties, or the exclusion of limitation of incidental or consequential damages, the above limitations or exclusions do not apply.

Some states do not allow limitations on how long an implied warranty lasts, or the exclusion of limitation of incidental or consequential damages, so the above limitations or exclusions may not apply to you.

This warranty gives Customer specific legal rights. Customer may also have other rights that may vary from state to state.

**SATELLITE RECEIVER WARRANTY**

See manufacturer's limited warranty policy. WS-MOBWARREREV 2 Rev.1/10

**INSTRUCTIONS**



**WINEGARD®**

MODELS RV-7012, RV-7032, RV-7042

Made in U.S.A.

**RV WALL PLATE/ POWER SUPPLY**

This unit is equipped with a polyswitch, (current limiting device), which will shut down +12VDC if there is a direct short between antenna and power supply. Green indicator light will not light. Once short is eliminated, device will reset itself in approximately 2 minutes.

**DESCRIPTION**

Wall plate/power supply to operate Winegard RV antenna with outdoor receptacle for TV set and cable input. Wall plate/power supply provides +12VDC to antenna and +12 volt receptacle as well as antenna signals to two TV sets. Cable input from outdoor receptacle connects to wall plate and may be switched so either antenna or cable or signals may be watched. See applications.

**NOTE: THIS UNIT IS NOT AN AMPLIFIER. USE ONLY WITH A WINEGARD AMPLIFIED RV ANTENNA.**

**WINEGARD COMPANY**

3000 KIRKWOOD ST., BURLINGTON, IA 52601-2000  
Printed in U.S.A. 2451486 Rev.2 1/10

**WARNING: Use of this on/off power switch with any product other than Winegard amplified RV antenna, could result in fire or other damage.**

**APPLICATIONS AND ALTERNATE CONNECTIONS**

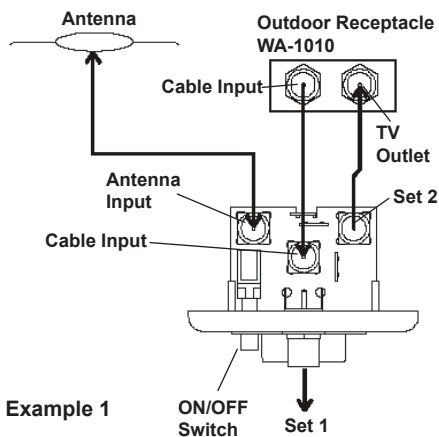

**WARNING: Do Not Connect High Current Devices Such as Hair Dryers to +12 Volt Receptacle on Wall Plate/Power Supply. Maximum current ratings of this receptacle is 7.5 amps at +12 VDC.**

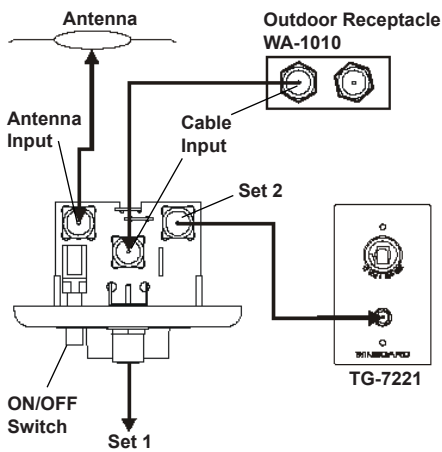

Example 2

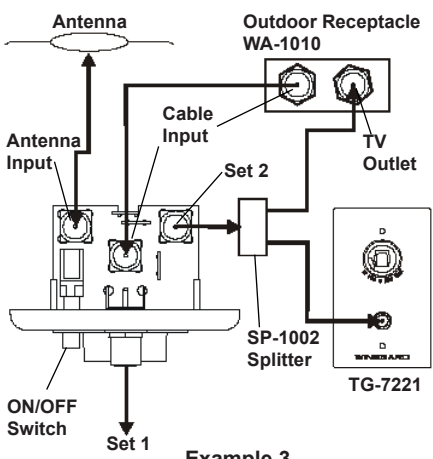

Example 3

**INSTRUCTIONS**

**STEP 1.** Select location for wall plate and patio receptacle. Run two coax cables between locations and install connectors on each end. **Mark cables so "cable input" and "TV output" may be identified.** Antenna download and +12 VDC will also be needed at inside wall plate/power supply location.

**STEP 2.** The wall plate/power supply assembly may be flush mounted in most standard electrical boxes. To flush mount cut a hole in wall to fit the box. Run 2 #12 wires between wall plate/power supply and +12VDC source and route download cable to this location. Install cable between set 2 outlet and power supply location at this time.

**WHEN CONNECTING CABLE OR WIRES BE SURE SWITCH IS IN OFF POSITION.**

**STEP 3.** Make +12 volt connection to wall plate/power supply Figure 2. Install terminals on wires from +12VDC source as shown in Figure 1. Crimp terminals with Craftsman type 4 crimping tool or equivalent. Push wires onto tabs on terminal board as shown in Figure 2. If in doubt as to the polarity of the wires, connect them temporarily to tabs on circuit board and press switch on front of outlet. If light comes on, polarity is correct. See Figure 3.

**STEP 4.** Install connectors on download and set 2 cable as shown in Figure 5. Attach download cable to jack on wall plate/power supply marked antenna as shown in Figure 4. Attach cable going to set 2 outlet to jack on power supply marked SET 2. Attach cable coming from cable input to jack on power supply marked CABLE.

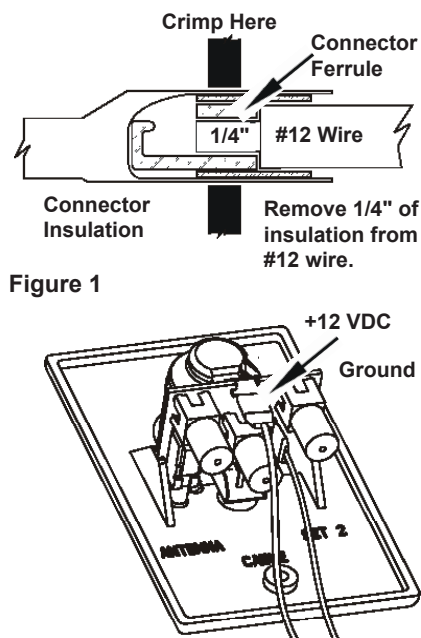

Figure 1

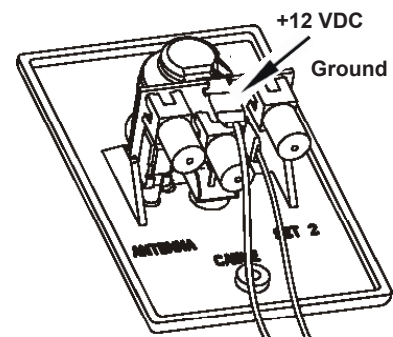

Figure 2

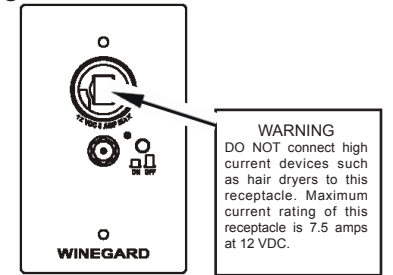
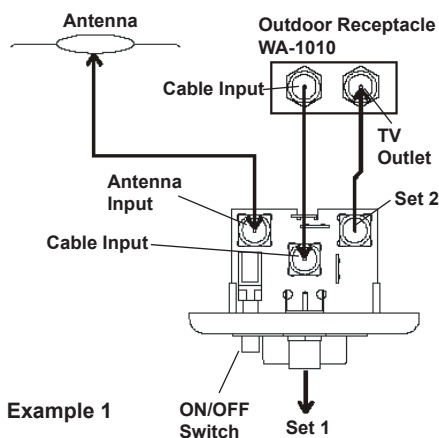

Figure 3

**WARNING: Use of this on/off power switch with any product other than Winegard amplified RV antenna, could result in fire or other damage.**

**APPLICATIONS AND ALTERNATE CONNECTIONS**



**WARNING: Do Not Connect High Current Devices Such as Hair Dryers to +12 Volt Receptacle on Wall Plate/Power Supply. Maximum current ratings of this receptacle is 7.5 amps at +12 VDC.**

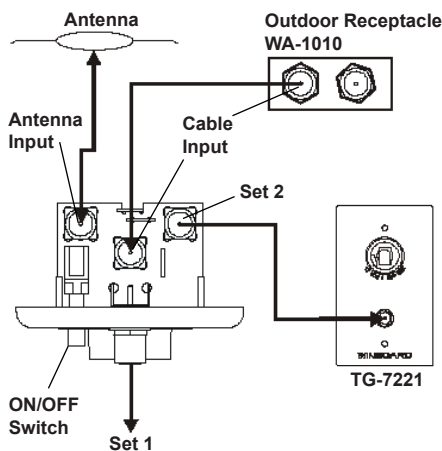

Example 2

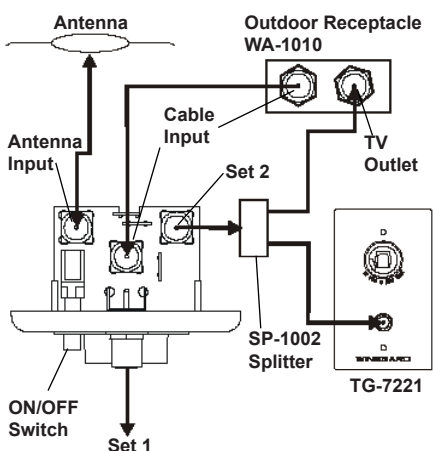

Example 3

**INSTRUCTIONS**

**STEP 1.** Select location for wall plate and patio receptacle. Run two coax cables between locations and install connectors on each end. **Mark cables so "cable input" and "TV output" may be identified.** Antenna download and +12 VDC will also be needed at inside wall plate/power supply location.

**STEP 2.** The wall plate/power supply assembly may be flush mounted in most standard electrical boxes. To flush mount cut a hole in wall to fit the box. Run 2 #12 wires between wall plate/power supply and +12VDC source and route download cable to this location. Install cable between set 2 outlet and power supply location at this time.

**WHEN CONNECTING CABLE OR WIRES BE SURE SWITCH IS IN OFF POSITION.**

**STEP 3.** Make +12 volt connection to wall plate/power supply Figure 2. Install terminals on wires from +12VDC source as shown in Figure 1. Crimp terminals with Craftsman type 4 crimping tool or equivalent. Push wires onto tabs on terminal board as shown in Figure 2. If in doubt as to the polarity of the wires, connect them temporarily to tabs on circuit board and press switch on front of outlet. If light comes on, polarity is correct. See Figure 3.

**STEP 4.** Install connectors on download and set 2 cable as shown in Figure 5. Attach download cable to jack on wall plate/power supply marked antenna as shown in Figure 4. Attach cable going to set 2 outlet to jack on power supply marked SET 2. Attach cable coming from cable input to jack on power supply marked CABLE.

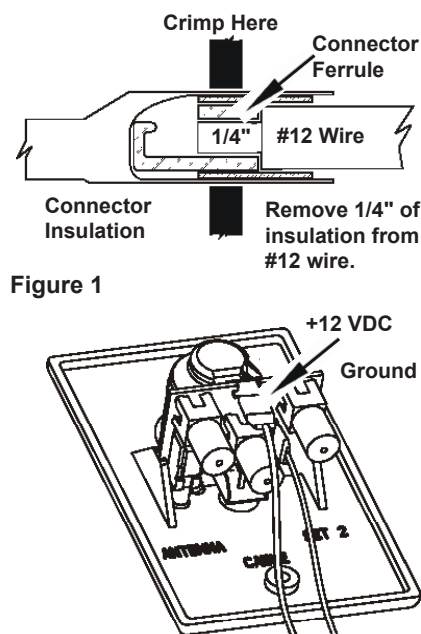

Figure 1

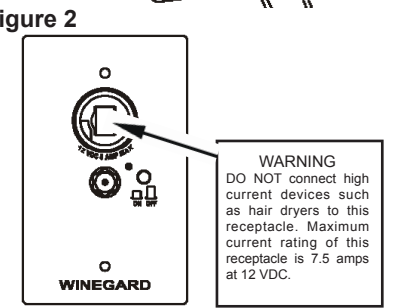

Figure 2

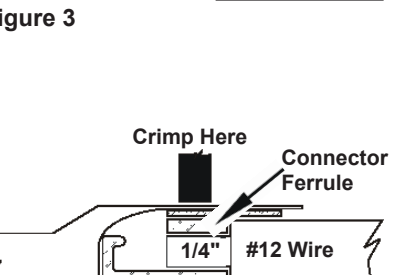
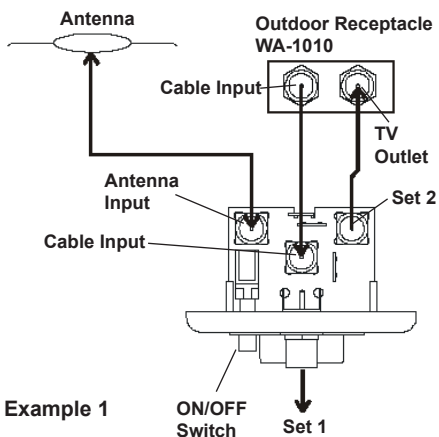

Figure 3

**WARNING: Use of this on/off power switch with any product other than Winegard amplified RV antenna, could result in fire or other damage.**

**APPLICATIONS AND ALTERNATE CONNECTIONS**



**WARNING: Do Not Connect High Current Devices Such as Hair Dryers to +12 Volt Receptacle on Wall Plate/Power Supply. Maximum current ratings of this receptacle is 7.5 amps at +12 VDC.**

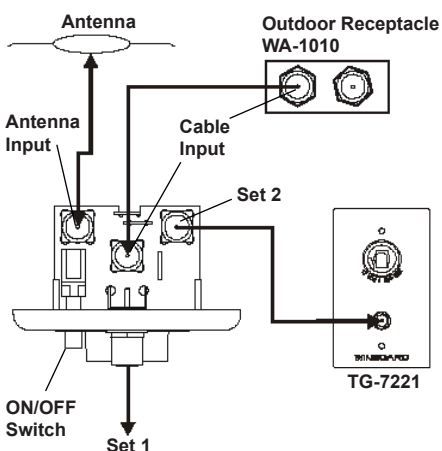

Example 2

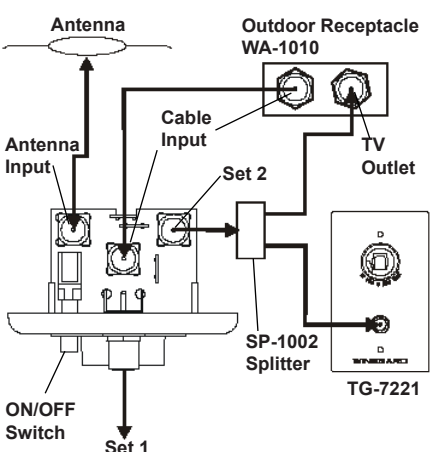

Example 3

**INSTRUCTIONS**

**STEP 1.** Select location for wall plate and patio receptacle. Run two coax cables between locations and install connectors on each end. **Mark cables so "cable input" and "TV output" may be identified.** Antenna download and +12 VDC will also be needed at inside wall plate/power supply location.

**STEP 2.** The wall plate/power supply assembly may be flush mounted in most standard electrical boxes. To flush mount cut a hole in wall to fit the box. Run 2 #12 wires between wall plate/power supply and +12VDC source and route download cable to this location. Install cable between set 2 outlet and power supply location at this time.

**WHEN CONNECTING CABLE OR WIRES BE SURE SWITCH IS IN OFF POSITION.**

**STEP 3.** Make +12 volt connection to wall plate/power supply Figure 2. Install terminals on wires from +12VDC source as shown in Figure 1. Crimp terminals with Craftsman type 4 crimping tool or equivalent. Push wires onto tabs on terminal board as shown in Figure 2. If in doubt as to the polarity of the wires, connect them temporarily to tabs on circuit board and press switch on front of outlet. If light comes on, polarity is correct. See Figure 3.

**STEP 4.** Install connectors on download and set 2 cable as shown in Figure 5. Attach download cable to jack on wall plate/power supply marked antenna as shown in Figure 4. Attach cable going to set 2 outlet to jack on power supply marked SET 2. Attach cable coming from cable input to jack on power supply marked CABLE.

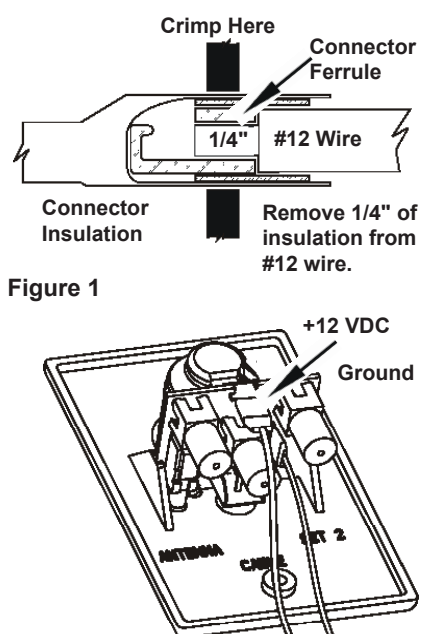

Figure 1

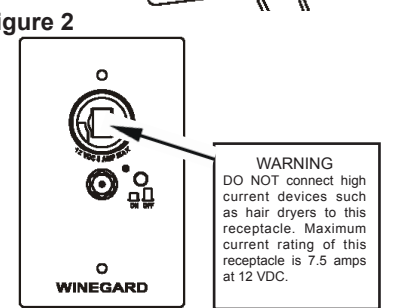

Figure 2



Figure 3